

The Compressibilities of the Chlorides, Bromides, and Iodides of Sodium, Potassium, Silver, and Thallium, THIS JOURNAL, 31, 158 (1909); *Z. physik. Chem.*, 71, 152 (1910) (with Grinnell Jones).

The Fundamental Properties of the Elements, Faraday Lecture, *J. Chem. Soc.*, 99, 1201 (1911); *Science, N. S.*, 34, 537 (1911); *Proc. Chem. Soc.*, 27, 177 (1911); *Rev. sci.*, 50, 321 (1912); *Smithsonian Report*, p. 199 (1912).

Compressibilities of Certain Hydrocarbons, Alcohols, Esters, Amines, and Organic Halides, THIS JOURNAL, 34, 971 (1912) (with W. N. Stull, J. H. Mathews, and C. L. Speyers).

Die Bestimmung der Kompressibilität flüssiger und fester Substanzen, Stähler's *Handbuch der Arbeitsmethoden in der anorganischen Chemie*, p. 247, Leipzig, 1912.

The Chemical Significance of Crystalline Form, THIS JOURNAL, 35, 381 (1913).

The Theory of Compressible Atoms, *Harvard Graduates' Magazine*, 21, 595 (1913).

The Compressibility of Ice, THIS JOURNAL, 36, 491 (1914) (with C. L. Speyers).

The Significance of the Quantity  $b$  in the Equation of Van der Waals, THIS JOURNAL, 36, 617 (1914).

Further Remarks on the Chemical Significance of Crystalline Form, THIS JOURNAL, 36, 1687 (1914).

WOLCOTT GIBBS MEMORIAL LABORATORY, HARVARD UNIVERSITY.

CAMBRIDGE, MASSACHUSETTS, Sept., 1914.

## STUDIES OF THE VAPOR PRESSURE OF SOLUTIONS. A STATIC METHOD FOR THE DETERMINATION OF THE DIFFERENCE BETWEEN THE VAPOR PRESSURE OF SOLUTION AND THAT OF SOLVENT.

By J. C. W. FRAZER AND B. F. LOVELACE.

Received October 12, 1914.

The fundamental importance of accurate determinations of the effect of dissolved substances on the vapor pressure of solvents, and the lack of agreement of results obtained by different workers using dynamic methods, led the authors, in the spring of 1912, to undertake the problem of improving the static method with the view of making it a method of precision. After some preliminary experiments, they decided to apply the principle of the Rayleigh manometer.<sup>1</sup>

This instrument was designed by Lord Rayleigh for the purpose of measuring small differences in gas pressure. It is used by the authors to measure the difference between the vapor pressure of the solution and that of the pure solvent. The work so far has been limited to aqueous solutions of mannite at 20°.

The essential features of the manometer are shown in Fig. 5. R R are glass bulbs, about 39 mm. in diam., blown on a glass fork. This is connected by means of a rubber tube with a mercury reservoir which may be adjusted very accurately at any desired height by means of the screw I. At the centers of the bulbs are set two glass points. The side limbs P P communicate with the systems, the relative pressures in which are to be measured.

<sup>1</sup> *Z. physik. Chem.*, 37, 713 (1901); *Trans. Royal Soc.*, 196, 205 (1901).

The bulbs are set in plaster in an iron pot, M, which is mounted on an axis, D, at right angles to the vertical plane passing through the points. This permits of rotation by means of the screw O.

Now, suppose the same pressure exists in the two bulbs. By manipulation of the two screws I and O, the one serving to regulate the height of the mercury and the other to rotate the manometer, the two points can readily be brought into coincidence with their images in the mercury. This is called the zero position.

Now, suppose the pressure in one bulb to be slightly increased. By readjustment of the mercury level and again rotating, the points can a second time be brought into coincidence with their images. It is obvious that, in order to calculate the difference in pressure in the two bulbs, it is necessary to know very accurately the distance between the points and the angle of rotation. The angle of rotation may be calculated from the length of the lever arm, and the rotation and pitch of the screw O. Or, following Rayleigh, we may determine the difference in pressure by means of a mirror, telescope and scale, and this is the method actually used. A  $\delta$  is a metallic mirror firmly mounted in a vertical plane perpendicular to the line joining the two glass points. The axis of rotation lies in the plane of the mirror. A telescope, with vertical scale, is mounted at a distance of a little over three meters in front of the mirror, the image of the scale being at all times visible through the telescope.

If  $d$  represents the distance between the points,  $D$  the distance from mirror to scale,  $\theta$  the angle of rotation from the zero position,  $h$  the difference in pressure in the two limbs of the manometer corresponding to this angle of rotation and  $S$  the scale deflection, then the following equations are obtained:

$$h = d \sin \theta \text{ and } S = D \tan 2\theta$$

and

$$h = \frac{ds}{2D} \frac{\sin \theta}{\frac{1}{2} \tan 2\theta}.$$

Now for all values of  $\theta$  up to  $1^\circ$ ,  $\frac{\sin \theta}{\frac{1}{2} \tan 2\theta}$  may be regarded as unity and our formula becomes,  $h = ds/2D$ . For the particular instrument being used in this work  $\theta = 1^\circ$  corresponds approximately to the depression of a 3-molar solution of a nonelectrolyte,  $d = 38.88$  mm. and  $D = 3350.6$  mm. Substituting these values and making  $S = 1$  we get  $h = \frac{38.88 \times 1}{2 \times 3350.6} = 0.00580$ . This means that 1 mm. scale deflection from zero position corresponds to a difference in pressure in the two bulbs of 0.00580 mm. By observing the points through microscopes of 25 mm. focus, mounted on the instrument and rotating with it, the operator can set the points to an accuracy of 0.1 mm. on the scale,

which corresponds to a difference in pressure of 0.00058 mm. This is the limit of accuracy of the instrument and is approximately that claimed by Rayleigh for his manometer, of which the one used in this work is practically a reproduction.

In using an instrument of such precision the authors are subjecting the static method of measuring vapor pressures to the severest test that could be applied. The results, however, have fully justified its use.

The two great difficulties involved in all static methods for the determination of vapor pressure of solutions, as pointed out by Ostwald and others, are:

1. The necessity for complete removal from the solution of constituents more volatile than the solvent, in particular, dissolved gases, and
2. The necessity of stirring the solution to prevent surface concentration.

In this work, before final observations are made, dissolved air is removed from both solution and solvent to such an extent that, after they have stood in a vacuum for at least forty-eight hours, the pressure due to air in the space above the liquid is negligible. Provision is also made for vigorous stirring always after any appreciable amount of vapor has left the solution. This stirring involves a complete renewal of the entire surface of the solution. The methods by which these two results are accomplished may be best seen by reference to Figs. 1-5, and to the following detailed description of the apparatus and method of manipulation:

#### The Apparatus.

The entire apparatus is built around the Rayleigh manometer, shown at F, Fig. 1. A more detailed sketch of the manometer is shown in Fig. 5. One side of the manometer communicates with the solvent bulb, H, and the other with the solution bulb I. 1, 2, 3, 4, 5, 6 are mercury traps which serve as stopcocks. They may be opened or closed by adjusting the position of the mercury reservoirs. The long ones are of barometer height, while the short ones are about 100 mm. high. Since ordinary stopcocks are not employed, the use of lubricant is avoided. The large bulb, B, is introduced to increase the capacity of the system and thus facilitate removal of air from solution and solvent. A is a phosphorus pentoxide bulb provided with a ground glass joint and mercury seal. C is the McLeod gage. All connecting tubes are seven mm. internal diameter.

After the apparatus was put together all parts of it except the Rayleigh manometer and the phosphorus pentoxide bulb were thoroughly steamed out.

The bulbs containing solution and solvent are immersed in a water bath, the temperature of which does not vary over periods of several hours more than 0.001°, as read on a Beckmann thermometer. Experience has shown that the Rayleigh manometer is quite sensitive to fluctuations

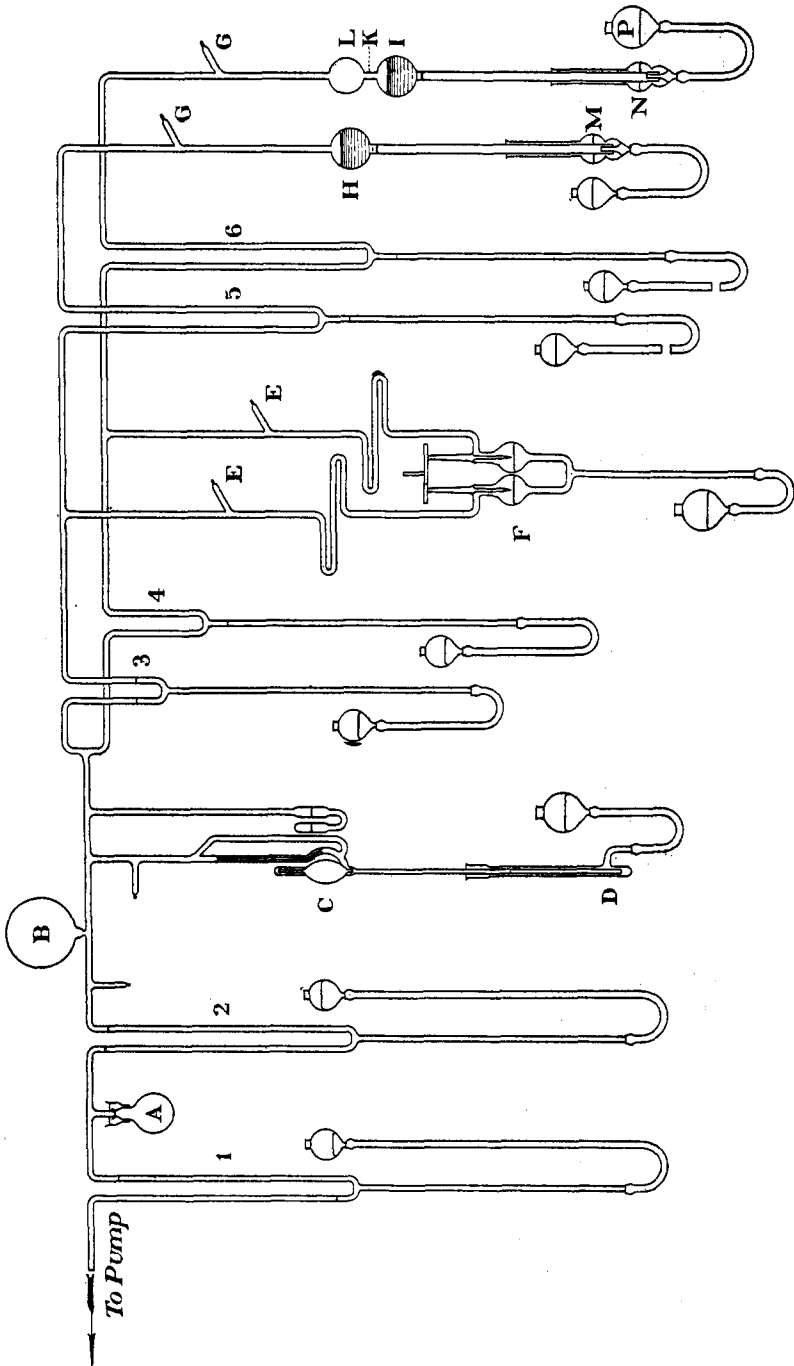

FIG. 1.

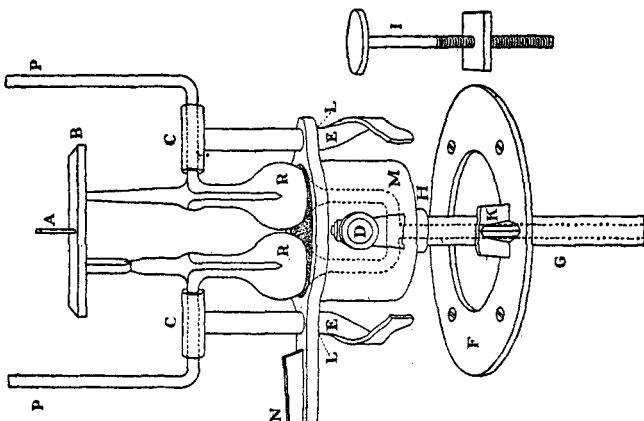

Fig. 5.



Fig. 4.

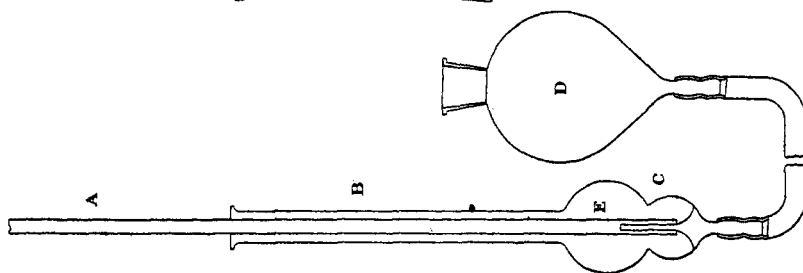

Fig. 3.

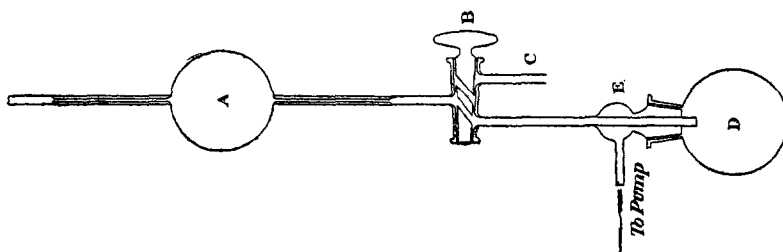

Fig. 2.

of  $0.003^{\circ}$  in the bath temperature, if these fluctuations occur over short intervals of time. That is to say, observations of pressure are not constant, if a Beckmann thermometer immersed in the bath shows variations of as much as  $0.003^{\circ}$ .

While it is thus necessary to avoid sensible variations in the temperature of the solution and solvent, no such constancy of temperature is necessary for the other parts of the system. Large or sudden variations of room temperature are of course to be avoided, but experience has shown that after complete removal of air, slight changes in room temperature do not affect the pressure in the system, and accordingly accurate regulation of room temperature is unnecessary. The temperature of the room is kept several degrees above that of the bath.

In carrying out a complete experiment the following procedure is adopted: The proper amount of carefully cleaned mercury is poured into each of the reservoirs attached to the open ends M and N of the apparatus and the entire system exhausted repeatedly to the highest vacuum attainable by the pump.<sup>1</sup> The zero point is then determined, after which solvent, partially freed from air by boiling, is introduced and the remaining trace of dissolved air removed, as described later. The solution, also partially freed from air, in a manner to be described later, is next introduced and, after complete removal of dissolved air, the zero point may be redetermined. Finally the pressure of vapor over the solution is balanced against that of the vapor over the solvent and the scale deflection read. A detailed description of these processes follows:

*The Solvent.*—The entire apparatus having been exhausted, trap 5 is closed and the solvent, freed from air as completely as possible by long boiling, is introduced into the bulb from below by means of the arrangement shown in Fig. 3. This is done as follows: A sealed bulb, similar to that shown in Fig. 4 containing air-free solvent, is placed between the mercury reservoir D (Fig. 3) and the trap C and the sealed ends broken off under mercury. Then, regulating pressure by means of the adjustable mercury reservoir, the solvent is forced through the tip and rises through the mercury to the bulb, shown at H in Fig. 1. In this operation the solvent need not come in contact with air and it is, therefore, possible to introduce into the apparatus solvent that is practically air-free. There is, however, in actual practice, always a trace of air to be removed after the solvent is in the bulb. This is accomplished in the following manner: Traps 1, 2 and 4 (Fig. 1) and the McLeod gage are closed, and trap 5 opened and allowed to stay open 24 hours. Trap 5 is then closed and 2 opened. After the absorption of water vapor by the phosphorus pentoxide in A is complete, the McLeod gage is opened and pressure determined.

<sup>1</sup> The pump used is Gaede's rotary mercury pump, with auxiliary oil pump, giving a vacuum of 0.00001 mm.

The residual air is pumped out and the process repeated as many times as may be necessary for complete removal of dissolved air. For practical purposes, the removal of air may be regarded "complete" when, on standing 48 hours in a vacuum, the amount of air given off by the water is so slight that it cannot be detected by means of the McLeod gage; that is, less than 0.0004 mm. The solvent having once been freed from air, may remain in the apparatus indefinitely and it is possible at any time to examine its vapor for air. Trap 3 is now closed and 5 opened.

*The Solution.*—Fig. 4 shows a device employed for partial removal of air from the solution before it is introduced into the apparatus. The bulb is drawn down at each end to a capillary and enough solution introduced, at the ordinary temperature, to fill the bulb completely at 85–90°. The lower capillary is then sealed off, the upper end drawn down to a very fine capillary, A, (about 0.05 mm.) and the whole heated to the temperature at which the solution completely fills the bulb and capillary. The latter is then sealed off and the solution allowed to cool and stand 24 hours in the partial vacuum thus obtained. The tip of the capillary is next broken off and the process repeated. Five repetitions of this operation are sufficient to remove nearly all the air. The solution is then introduced into the bulb I without coming in contact with the air and the last traces of dissolved air removed in the manner already described for the solvent. The extent to which the solution is concentrated during the process of removal of air after introduction into the bulb I may be accurately calculated and never exceeds 0.1%. After the removal of air is complete, trap 4 is closed and 6 opened, and a measurement may now be taken.

Observations on the Rayleigh manometer during the progress of the removal of air from the solution are very interesting. It is to be remembered that at this stage the vapor pressure of the air-free solvent is balanced against the pressure over the solution, which is equal to the vapor pressure of the solution plus a small air pressure. As long as any air remains in the solution, even the smallest trace, a very long time is necessary for the establishment of equilibrium after the opening of trap 6. The pressure in the solution limb of the manometer, at first very nearly the true vapor pressure of the solution, slowly increases for 24 or 48 hours, depending on how much air remains. After equilibrium is attained, the difference in pressure in the two limbs is read in the usual way by noting the scale deflection. To this apparent depression is added the air pressure in the system, subsequently determined by means of the McLeod gage, after absorption of the water vapor by the phosphorus pentoxide. The depression thus obtained agrees very closely, to about 0.001 mm., with the true depression measured later, after complete removal of air. The following data taken from the laboratory note-book will illustrate this:

*Experiment.*—150 cc. solution (0.4 *M* mannite) containing a trace of air were introduced at 11.30 A.M., Jan. 8th.

*First Exhaustion.*—Trap 4 opened at 12.15 P.M. and solution stirred. Scale Readings, Rayleigh Manometer:

|       |      |      |           |         |           |
|-------|------|------|-----------|---------|-----------|
| 12.30 | 2.15 | 5.00 | 8.00 P.M. | Jan. 9, | 9.25 A.M. |
| 51.3  | 51.0 | 48.5 | 46.0      |         | 45.0 mm.  |

Total time, 22 hours, zero 38.0, deflection 7 mm., air pressure 0.054 mm.

*Second Exhaustion.*—Trap 4 opened at 2.40 P.M., Jan. 9th. Scale Readings:

|      |      |      |           |            |      |            |
|------|------|------|-----------|------------|------|------------|
| 3.25 | 3.40 | 4.15 | 5.30 P.M. | Jan. 10th, | 8.45 | 10.20 A.M. |
| 57.0 | 56.6 | 55.8 | 54.0      |            | 49.5 | 49.0 mm.   |

Total time 20 hours. Pressure due to air not read.

*Third Exhaustion.*—Trap 4 opened at 2.15 P.M., Jan. 10th. Scale Readings:

|      |      |      |           |            |            |           |            |           |
|------|------|------|-----------|------------|------------|-----------|------------|-----------|
| 2.20 | 2.25 | 3.00 | 4.00 P.M. | Jan. 11th, | 10.30 A.M. | 7.30 P.M. | Jan. 12th, | 8.30 A.M. |
| 60.1 | 59.4 | 58.0 | 56.0      |            | 53.0       | 53.0      |            | 52.7 mm.  |

Total time 42 hours.

Deflection 15 mm.

Air pressure..... 0.036 mm.

Apparent depression..... 0.087

Correction for air..... 0.036

Corrected depression..... 0.123

*Fourth Exhaustion.*—Trap 4 opened at 11.30 A.M., Jan. 12th. Scale readings:

|          |       |      |      |           |            |      |            |           |
|----------|-------|------|------|-----------|------------|------|------------|-----------|
| 12.00 M. | 12.30 | 2.00 | 3.00 | 4.15 P.M. | Jan. 13th, | 9.00 | 10.20 A.M. | 2.00 P.M. |
| 59.2     | 59.2  | 59.1 | 58.9 | 58.7      |            | 58.0 | 57.9       | 57.9 mm.  |

Total time 26 hours.

Deflection 20 mm.

Air pressure..... 0.0068

Apparent depression..... 0.116

Correction for air..... 0.007

Depression..... 0.123

*Fifth Exhaustion.*—Trap 4 opened at 5.00 P.M., Jan. 13th. Scale readings:

|      |           |            |           |       |           |
|------|-----------|------------|-----------|-------|-----------|
| 5.15 | 7.45 P.M. | Jan. 14th, | 9.45 A.M. | 12.40 | 3.15 P.M. |
| 61.0 | 59.7      |            | 59.1      | 59.5  | 59.3 mm.  |

Time 23 hours.

Air pressure..... 0.000

Depression..... 0.124 mm.

The true depression, as later determined, was 0.122 mm.

The gradual development of pressure in the solution side of the manometer, as seen in the first four exhaustions, was due to the slow escape of dissolved air. The air pressure developed, however, became less with each exhaustion; still, even in the fourth exhaustion, when the equilibrium pressure of air was very small, a very long time was necessary for complete equilibrium to be established. When the solution becomes air-free, equilibrium is always reached in from 15–20 minutes.

It should be pointed out that the foregoing figures, obtained during the time air is being removed from the solution, are not regarded as final. No attempt is made to regulate the bath temperature with any great accuracy while air is being removed, the variations sometimes amounting



to  $0.005^{\circ}$  during this operation, and no special effort was expended to make the above measurements anything more than approximately correct. Final measurements are always made after no more air can be pumped off from the solution and while these final measurements are being made the bath temperature never varies more than  $0.001^{\circ}$  over periods of several hours.

When the apparatus was being built the McLeod gage was included in the system for the purpose of showing when the removal of air was complete. As a matter of fact, however, the gauge is not necessary for this purpose. Given an air-free solvent in one bulb, the operator can follow very closely the progress of removal of air from the solution in the other bulb by observations on the Rayleigh manometer and can tell infallibly, without use of the McLeod gage, when the removal of air is complete.

*Stirring the Solution.*—Efficient stirring of the solution is desirable because it facilitates the removal of air; it is necessary, when readings are to be made, in order to destroy the surface concentration of the solution resulting from evaporation. The device shown in Fig. 3, which permits the introduction of the solution as has already been described, also serves as a means of stirring. The stirring is brought about by simply raising and lowering the mercury in the reservoir P, Fig. 1. About one-half of the solution is in this way forced through the constriction K into the upper bulb L, and back again. Several repetitions of this procedure insure practically complete uniformity of concentration throughout the whole solution.

The apparatus shown in Fig. 2 was devised for the purpose of preparing the solution in a vacuum.

### Experimental.

We give below the results of two experiments with aqueous solutions of mannite. The solutions are made up on the weight-normal basis; that is, by a molar solution is meant one containing a gram molecular weight of solute in one thousand grams of solvent. In making up the solutions, allowance is made for the known amount of solvent that is to be lost during subsequent removal of dissolved air, and the concentrations given are the concentrations at the time final observations are made.

#### *Experiment 3.*— $0.5 M$ mannite.

The solution was introduced into the apparatus on the afternoon of November 12, 1913. On November 20, the air was completely removed. This solution was under examination throughout the month of December and in January the following final observations were made.

It will be observed that each of the above experiments lasted about eight weeks. The object of continuing observations over such long periods was, once for all, to make a thorough investigation of all sources of error

*Experiment 3*, using 0.5 M mannite.

Solution introduced Nov. 12, 1913. Removal of air complete Nov. 20th. Final observations as follows:

|      |   |                                 |      |      |      |      |      |      | Mean. | Deflection. |
|------|---|---------------------------------|------|------|------|------|------|------|-------|-------------|
| Jan. | 1 | Zero at varying intervals.....  | 37.9 | 37.9 | 37.9 | ..   | ..   | ..   | ..    | } 37.97     |
| Jan. | 2 |                                 | 37.8 | 38.0 | 37.9 | 38.0 | 38.1 | 38.2 | 38.0  |             |
|      |   | Reading (5 min. intervals)..... | 64.8 | 64.8 | 64.9 | ..   | ..   | ..   | ..    | } 64.83     |
| Jan. | 3 | Reading (5 min. intervals)..... | 64.9 | 65.0 | 64.9 | ..   | ..   | ..   | ..    |             |
|      |   | Zero (5 min. intervals).....    | 38.0 | 38.0 | 38.0 | ..   | ..   | ..   | ..    | } 38.00     |
| Jan. | 5 | Reading.....                    | 64.9 | 64.9 | 65.0 | ..   | ..   | ..   | ..    |             |
|      |   | Zero.....                       | 38.0 | 38.0 | 38.0 | ..   | ..   | ..   | ..    | } 38.00     |

Mean Deflection 26.91. Depression 26.91 × 0.00580 = 0.156 mm. Temp. 20.036°.

*Experiment 4*, using 0.4 M mannite.

Solution introduced Jan. 8, 1914. Removal of air complete Jan. 16th. Final observations as follows:

|       |    |                                     |      |      |      |      |      |      |      |         |
|-------|----|-------------------------------------|------|------|------|------|------|------|------|---------|
| Jan.  | 22 | Reading (at various intervals)..... | 58.9 | 58.9 | 58.9 | 58.9 | 58.9 | 58.8 | 58.9 | } 58.9  |
|       |    | Zero.....                           | 38.0 | 38.0 | 38.0 | ..   | ..   | ..   | ..   |         |
| Jan.  | 24 | Zero.....                           | 37.9 | 37.9 | 38.0 | ..   | ..   | ..   | ..   | } 37.93 |
|       |    | Reading.....                        | 58.9 | 59.0 | 59.1 | ..   | ..   | ..   | ..   |         |
| Jan.  | 27 | Reading.....                        | 58.8 | 58.8 | 59.0 | ..   | ..   | ..   | ..   | } 58.87 |
|       |    | Zero.....                           | 38.0 | 38.0 | 38.0 | ..   | ..   | ..   | ..   |         |
| Jan.  | 28 | Zero.....                           | 38.0 | 38.0 | 38.0 | ..   | ..   | ..   | ..   | } 38.0  |
|       |    | Reading.....                        | 59.0 | 58.9 | 59.0 | 59.0 | 59.0 | 58.9 | ..   |         |
| Feb.  | 5  | Reading.....                        | 58.8 | 59.0 | 58.8 | 58.8 | ..   | ..   | ..   | } 58.85 |
|       |    | Zero.....                           | 37.8 | 37.9 | 37.8 | ..   | ..   | ..   | ..   |         |
| Feb.  | 6  | Reading.....                        | 59.0 | 58.9 | 59.0 | 59.0 | 59.0 | 59.0 | ..   | } 59.0  |
|       |    | Zero.....                           | 38.0 | 38.0 | 38.0 | ..   | ..   | ..   | ..   |         |
| Feb.  | 14 | Reading.....                        | 59.0 | 59.0 | 59.0 | ..   | ..   | ..   | ..   | } 59.0  |
|       |    | Zero.....                           | 37.9 | 38.0 | 37.9 | ..   | ..   | ..   | ..   |         |
| Feb.  | 28 | Reading.....                        | 58.0 | 58.0 | 58.0 | 58.0 | ..   | ..   | ..   | } 58.0  |
|       |    | Zero.....                           | 37.0 | 37.0 | 37.0 | ..   | ..   | ..   | ..   |         |
| March | 2  | Reading.....                        | 58.2 | 58.0 | 58.0 | 58.0 | ..   | ..   | ..   | } 58.05 |
|       |    | Zero.....                           | 37.0 | 37.0 | 37.0 | ..   | ..   | ..   | ..   |         |
| March | 3  | Reading.....                        | 58.0 | 58.1 | 58.1 | ..   | ..   | ..   | ..   | } 58.06 |
|       |    | Zero.....                           | 37.0 | 37.0 | 37.0 | ..   | ..   | ..   | ..   |         |

Mean of all observations (Jan. 28-Mar. 3) Deflection 21.03; Depression 21.03 × 0.0058 = 0.122 mm. Temp. 20.008°.

and to determine the limits of accuracy of the method. These experiments have shown conclusively that:

1. Variations of temperature of solution and solvent must not exceed  $0.002^{\circ}$ .

2. Accurate regulation of the temperature of other parts of the apparatus, *i. e.*, those parts containing vapor, is unnecessary. This is because, when all air has been eliminated, equilibrium between solution and vapor is very quickly established, so that slight changes of temperature, unless they are too sudden, merely cause evaporation or condensation of slight amounts of water, without affecting pressure. If the system contains air, a change of temperature will produce change in pressure and such fluctuations are quite noticeable even with a very small amount of air.

3. If the temperature of the bath is controlled to within  $0.001^{\circ}$ , readings of pressure are constant to within  $0.001$  mm.

The authors believe that the measurements recorded above differ from the true values by not more than  $0.001$  mm. and are convinced that, with certain minor changes, the method is capable of giving results which are accurate to the third decimal place.

The experiments recorded above were made in collaboration with Mr. E. Miller who is continuing the work, and the authors expect to investigate solutions of both electrolytes and nonelectrolytes in various solvents.

JOHNS HOPKINS UNIVERSITY,  
BALTIMORE, MD.

---

## VAPOR PRESSURES OF CERTAIN ALCOHOLIC SOLUTIONS.

BY O. F. TOWER AND A. F. O. GERMANN.

Received October 17, 1914.

In a former paper one of us described a method for measuring vapor pressures by means of the Morley gage.<sup>1</sup> Satisfactory results were obtained with aqueous solutions, but with non-aqueous solutions certain difficulties were encountered which rendered the results that were reported at that time of little value. Moreover, the opinion was expressed that possibly the air-bubbling method would yield better results with this latter class of solutions. Numerous trials since then have, however, convinced us that it has no advantages over the method with the Morley gage, except at temperatures above room-temperature, and, besides, it possesses some disadvantages of its own which have caused us to return to the method with the Morley gage. The present paper, therefore, describes certain improvements in the apparatus and method of treatment of the solutions in determining the vapor pressures of non-aqueous solutions by this method.

The gage and the method of carrying out the readings were described

<sup>1</sup> O. F. Tower, THIS JOURNAL, 30, 1219 (1908).